



Lecture (10)

Practical Applications on Arduino Uno Board - III

Dr. Ahmed ElShafee

Dr. Ahmed ElShafee, ACU Spring 2013, Practical App. CS II

Agenda

- *
- *
- *

DimmerDCLamp

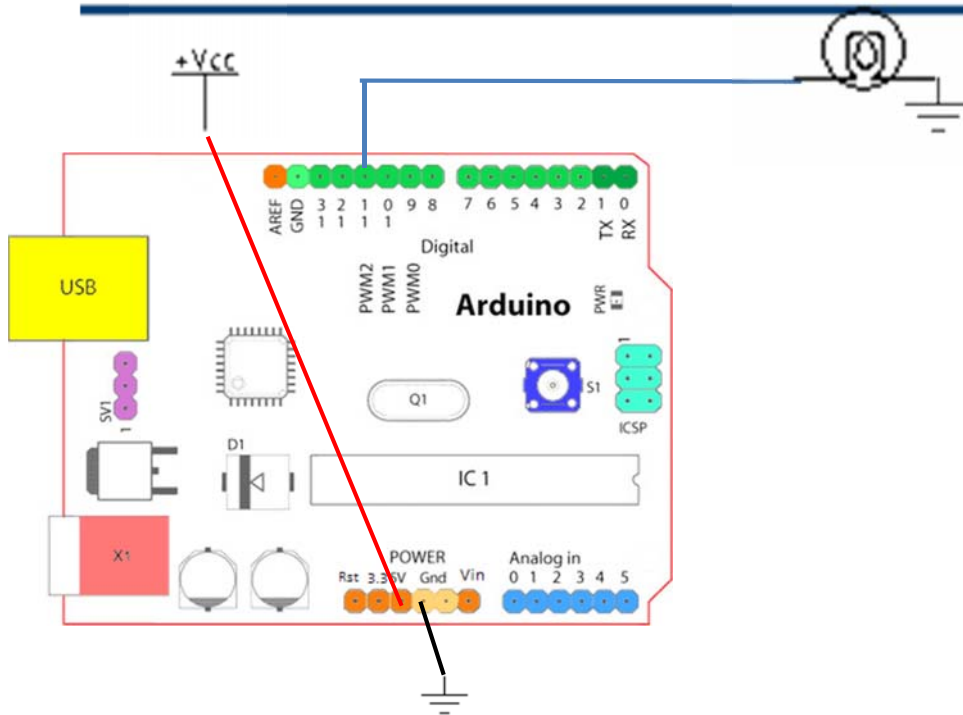

Dr. Ahmed ElShafee, ACU Spring 2013, GP2013

```
#define LED 11
int i;
void setup()
{
  pinMode(LED,OUTPUT);
}

void loop()
{
  for(i=0;i<=255;i++)
  {
    analogWrite(LED,i);
    delay(10);
  }
}
```

```
for(i=255;i>=0;i--)
{
  analogWrite(LED,i);
  delay(10);
}
```

DimmerDCLamp2

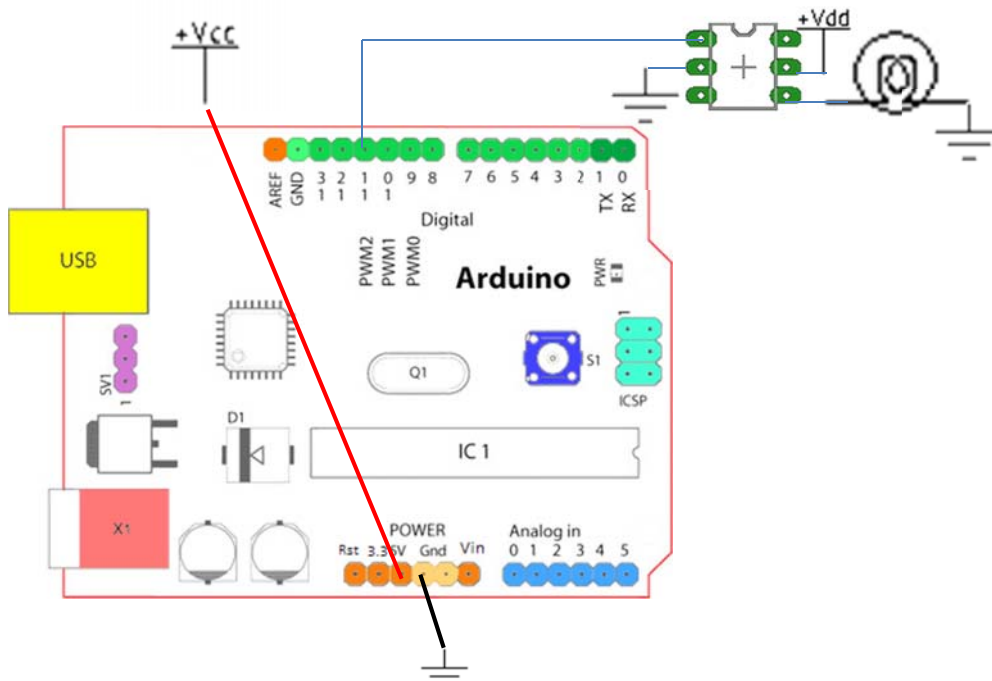

Dr. Ahmed ElShafee, ACU Spring 2013, Practical App. CS II

```
#define LED 11
int i;
void setup()
{
  pinMode(LED,OUTPUT);
}
void loop()
{
  for(i=0;i<=77;i++)
  {
    analogWrite(LED,i);
    delay(10);
  }
  for(i=77;i>=0;i--)
  {
    analogWrite(LED,i);
    delay(10);
  }
}
```

Dr. Ahmed ElShafee, ACU Spring 2013, Practical App. CS II

PressControlledDimmerDCLamp

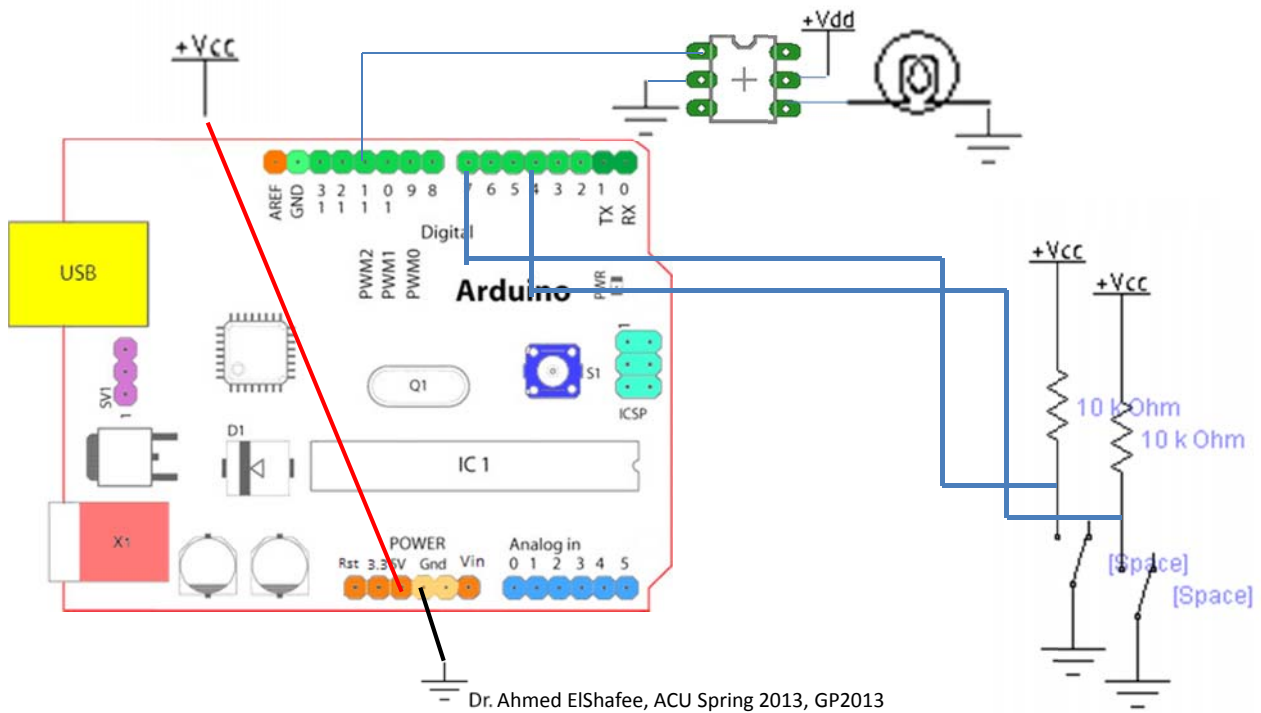

Y

```
#define Lamp 11
#define up 7
#define down 4
int up_status;
int down_status;
int i=0;
void setup()
{
  pinMode(Lamp,OUTPUT);
  pinMode(up,INPUT);
  pinMode(down,INPUT);
}
void loop()
{
  up_status=digitalRead(up);
  down_status=digitalRead(down);
```

```
if(up_status==LOW)
{
  if(i<128)
    i++;
}
else if(down_status==LOW)
{
  if(i>0)
    i--;
}
analogWrite(Lamp,i);
Delay(10);
}
```

A

Potentiometer Controlled Dimmer DC Lamp

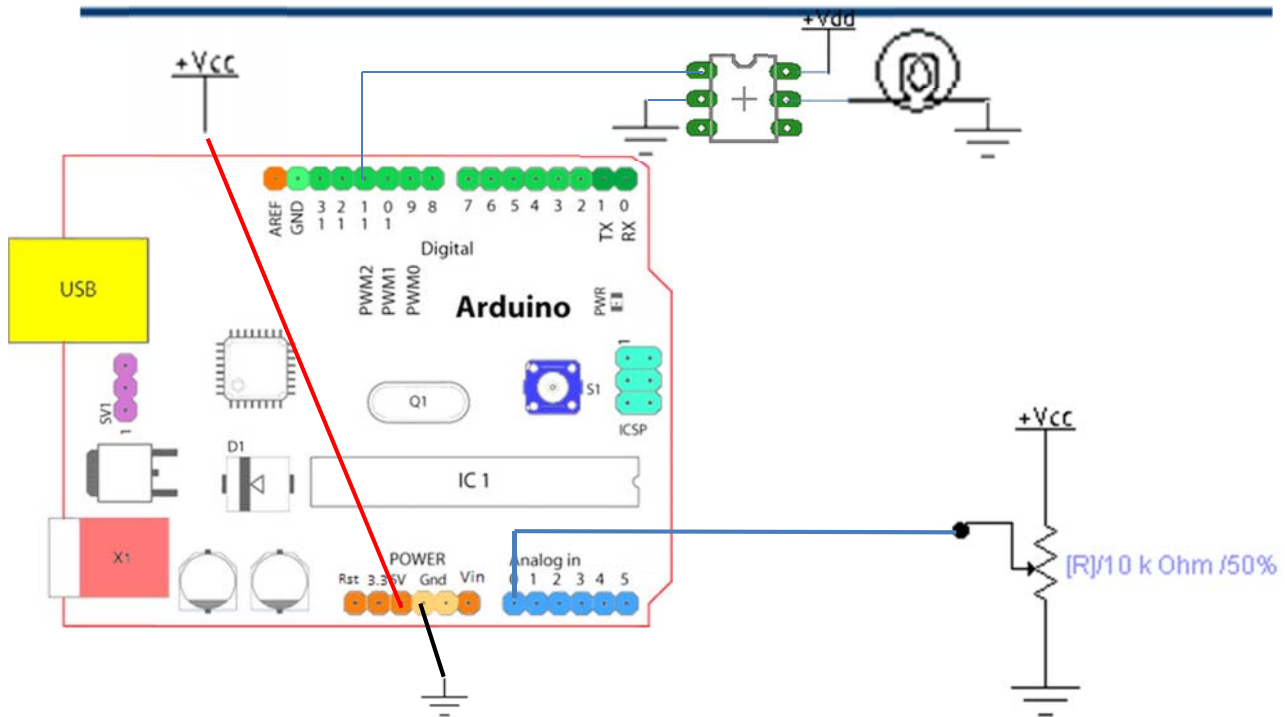

9

Dr. Ahmed ElShafee, ACU Spring 2013, GP2013

```
#define Lamp 11
#define Potentiometer A0
int pot,Imp;
void setup()
{
  pinMode(Lamp,OUTPUT);
  pinMode(Potentiometer,INPUT);
}
void loop()
{
  pot=analogRead(Potentiometer);
  Imp=int(pot*1.5/5/4);
  analogWrite(Lamp,Imp);
}
```

10

Dr. Ahmed ElShafee, ACU Spring 2013, GP2013

LDRControlledDCLamp

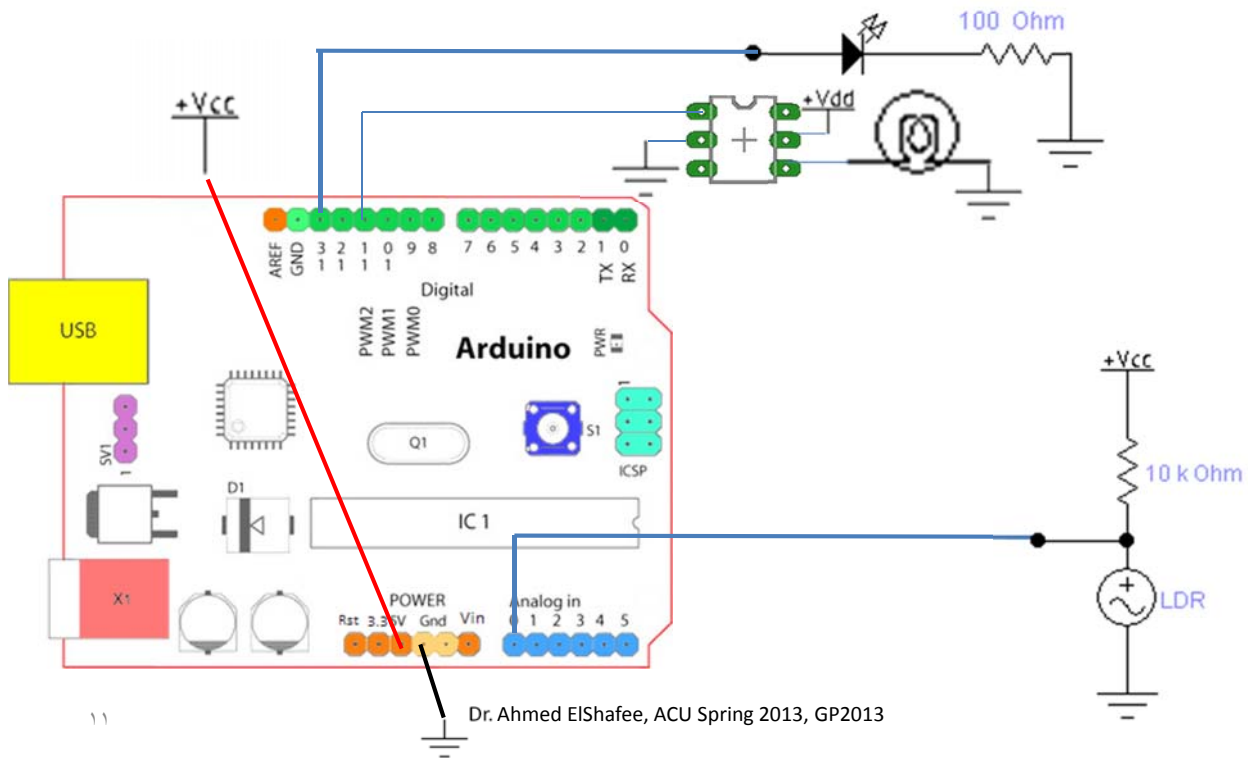

```

#define LAMP 11
#define LED 13
#define LDR A0
int pot,Imp;
void setup()
{
  pinMode(LED,OUTPUT);
  pinMode(LAMP,OUTPUT);
  pinMode(LDR,INPUT);
}
void loop()
{
  pot=analogRead(LDR);
  Imp=abs(byte(pot*1.5/5/4));
  if(Imp>50)
  {
    analogWrite(LAMP,Imp);
    digitalWrite(LED,HIGH);
  }
}

```

```

else
{
  analogWrite(LAMP,0);
  digitalWrite(LED,LOW);
}
}

```

Thanks,
See you next Week, isA